

GENTHERM

Technology to the next degree™

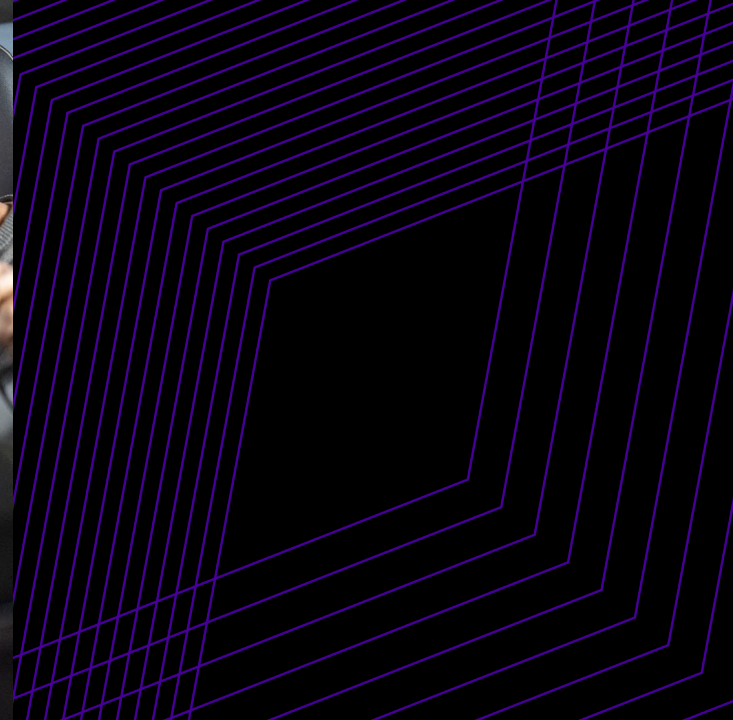

2024 J.P. Morgan Auto Conference

Phil Eyler, President and CEO

Matteo Anversa, Executive Vice President of Finance, Chief Financial Officer and Treasurer

Gentherm, Inc. | August 8, 2024

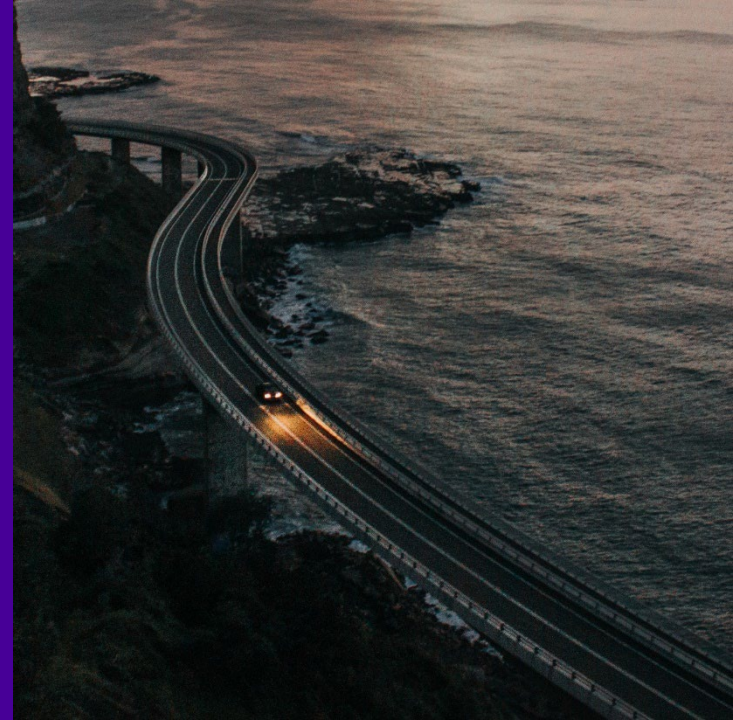

Use of Non-GAAP Financial Measures*

During this presentation, the Company may discuss adjusted earnings before interest, taxes, depreciation and amortization (“Adjusted EBITDA”); Adjusted EBITDA margin; adjusted earnings per share (“Adjusted earnings per share” or “Adjusted EPS”); free cash flow; Net Debt; revenue, segment revenue and product revenue excluding foreign currency translation and other specified gains and losses; Automotive Climate and Comfort Solutions revenues; and adjusted operating expenses, each a non-GAAP financial measure. See the Company’s earnings release dated July 31, 2024, for the definitions of each non-GAAP financial measure, information regarding why the Company utilizes such non-GAAP measures as supplemental measures of performance or liquidity, and their limitations, and for certain reconciliations of GAAP to non-GAAP historical financial measures.

* Reconciliations of GAAP to non-GAAP historical financial measures can be found in the Company’s quarterly earnings releases and related filings with the Securities and Exchange Commission.

Forward-Looking Statement

Except for historical information contained herein, statements in and during this presentation are forward-looking statements that are made by Gentherm Incorporated (the “Company”) pursuant to the safe harbor provisions of the Private Securities Litigation Reform Act of 1995. All statements that address future operating, financial or business performance or strategies or expectations are forward-looking statements. Such forward-looking statements are made as of the date hereof or as of the specified and are based on management's reasonable expectations and beliefs. In making these statements we rely on assumptions and analysis based on our experience and perception of historical trends, current conditions and expected future developments, as well as other factors we consider appropriate under the circumstances. Except as required by law, the Company expressly disclaims any obligation or undertaking to update any forward-looking statements to reflect any change in its strategies or expectations with regard thereto or any change in events, conditions or circumstances on which any such statements are based. The forward-looking statements are subject to a number of important assumptions, risks, uncertainties and other factors that may cause actual results or performance to differ materially from that expressed or implied by such statements. For a discussion of these risks and uncertainties and other factors, please see the Company’s most recent Annual Report on Form 10-K and subsequent filings with the Securities and Exchange Commission, including “Risk Factors.” In addition, the business outlook discussed in this presentation does not include the potential impact of any business combinations, acquisitions, divestitures, strategic investments and other significant transactions that may be completed after the date hereof, each of which may present material risks to the Company’s future business and financial results.

Why Gentherm



Pure play leader in thermal management and pneumatic comfort



Global automotive market is large with rapidly growing penetration of thermal and pneumatic solutions



Unique, innovative, energy efficient and software driven solutions key to vehicles of the future



Consistent execution against strategic plan with financial discipline

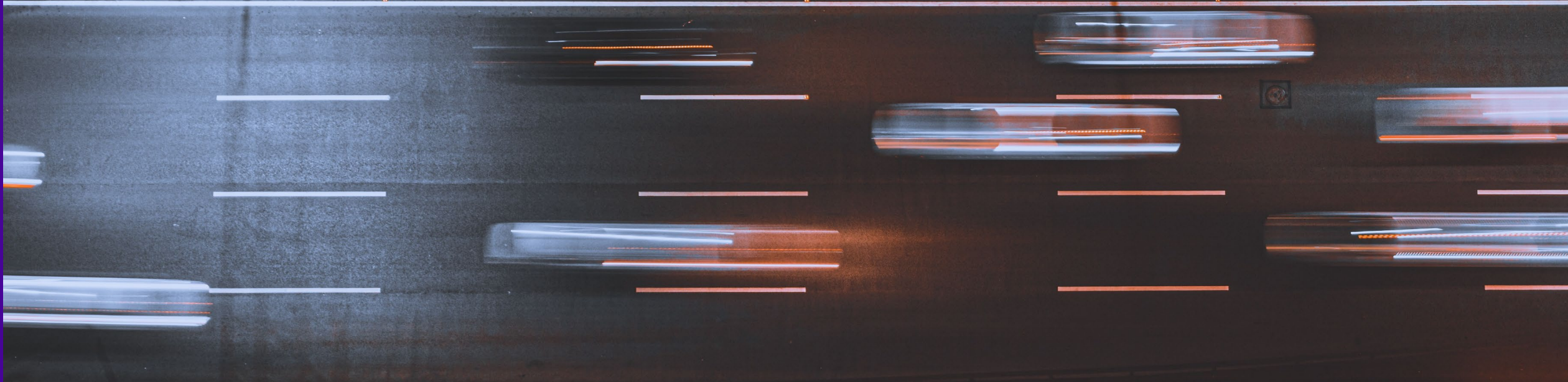

Poised for high-return growth and outpacing the market

Winning at Record Pace

✓ Expanding core thermal



CCS[®] expanding in each region, including fast growing domestic Chinese OEMs; significant growth in hands-on-detection enabled steering wheel heaters

✓ Growing market share in pneumatic



Won conquest pneumatic lumbar and massage awards with 9 OEMs globally leveraging the Alfmeier acquisition

✓ Leading supplier of combined systems

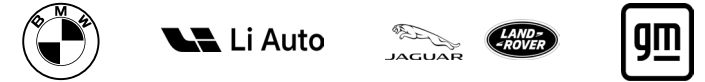

Won customer programs with combined thermal and pneumatic lumbar / massage solutions

✓ Increasing vehicle content



Leveraging ClimateSense[®] and WellSense[™] to increase vehicle content, demonstrated by new business wins

✓ Differentiating with software



ClimateSense[®] software enabling software defined vehicles

Independent partnership model leading to record wins and deeper customer relationships

Industry Leading Innovations

GENTHERM

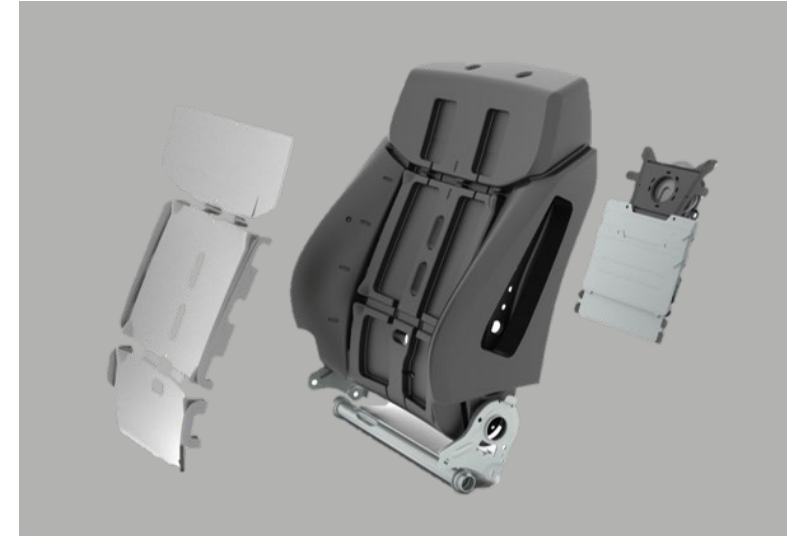
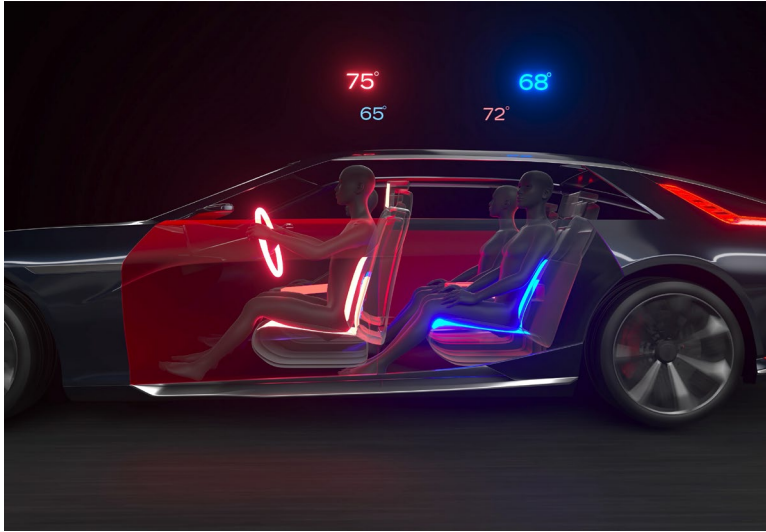

ClimateSense®

- Best-in-class software controlled thermal comfort
- Enhances energy efficiency and vehicle range
- Personalized microclimate

WellSense™

- Combines thermal, lumbar and massage
- Proprietary software driven wellness and alertness features
- Enabling software defined vehicles

ComfortScale™

- Modular and scalable hardware
- Easy to integrate across OEMs and Tier 1s
- Enhanced cost efficiency

Increasing content per vehicle with differentiated and proprietary solutions; well positioned to capitalize on the software defined vehicles of the future

First ComfortScale™ Award

GENTHERM

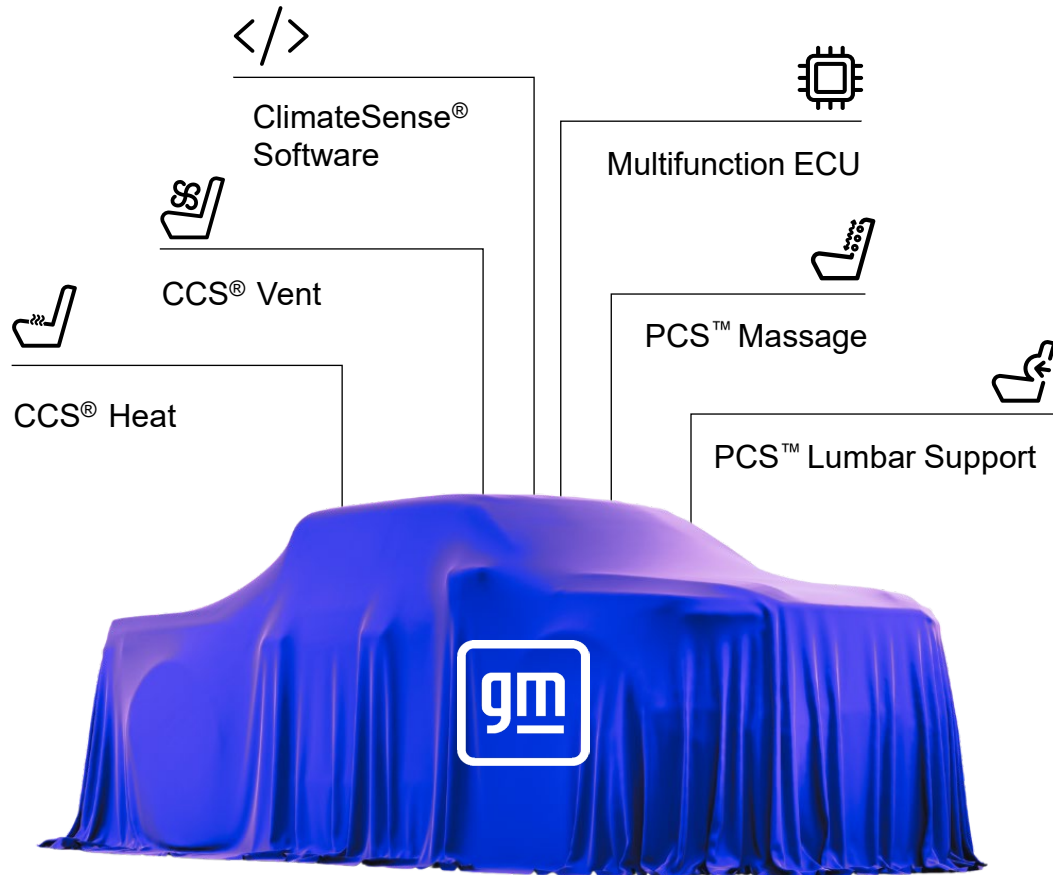

General Motors: Truck platform including Chevrolet Silverado & GMC Sierra

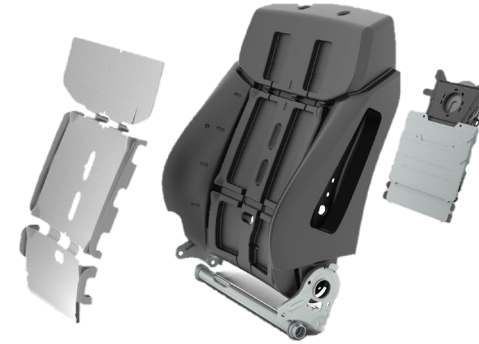

01

Flexible design provides ability to be foam and seat agnostic, adaptable for all OEMs and Seat Tier 1's

02

Unmatched performance with demonstratable improvement in time to occupant comfort resulting in an enhanced user experience

03

Scalable system from lumbar only to fully contented pneumatic and thermal solutions

04

Easy and quick to integrate design enables running changes

05

Lower cost and complexity reducing seat assembly time for JIT partners

Our fully integrated modular thermal and pneumatic lumbar and massage solution creates customer value and adds content per vehicle

Why Gentherm



Pure play leader in thermal management and pneumatic comfort



Global automotive market is large with rapidly growing penetration of thermal and pneumatic solutions



Unique, innovative, energy efficient and software driven solutions key to vehicles of the future



Consistent execution against strategic plan with financial discipline

A blurred image of a car's interior, showing the dashboard, steering wheel, and seats, with light trails suggesting motion or a futuristic theme.

Poised for high-return growth and outpacing the market